

TEJIDOS DE
SANTA ANA
TLACOTENCO

POR

JOAQUIN
GALLARZA

DIBUJOS

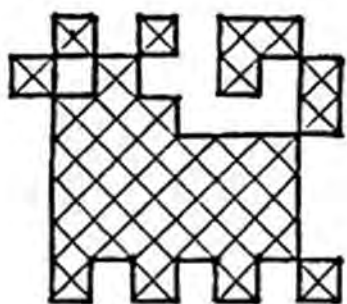

TRADICIONALES

CONVALES

Esta versión digital del mítico libro "Dibujos tradicionales" de Joaquín Galarza publicado por primera vez en 1982 por el CIESAS y después por Amatl en 1996 se presenta ahora en forma de compilación por la Sociedad de Experimentación. Forma parte de las tareas del colectivo por preservar documentos de la cultura de la región y fue realizada a petición de las y los tejedores al reconocer su aporte para continuar con la tradición y la cosmovisión en torno a los textiles y su dificultad para encontrarlo en librerías y bibliotecas.

Los diseños de los bordados y tejidos contenidos en esta compilación corresponden a los derechos de los pueblos y comunidades indígenas nahuas a las que pertenecemos.

Comparte y distribuye esta versión sin lucro por su reproducción.

Xochimilco, Diciembre, 2020.

Coordinación: Lucy Pereyra



Primera edición: 1982

Centro de Investigaciones y Estudios
Superiores en Antropología Social.

Cuadernos de la Casa Chata

Hidalgo y Matamoros, Tlalpan

México 22, D.F.

Tels. 573-43-18 y 573-28-77

AGRADECIMIENTOS 1996

En el volumen I de esta serie: Tlacotenco, Tonantzin Santa Ana [C.I.E.S.A.S. cuadernos, 49] citamos en detalle a las instituciones y personas francesas y mexicanas que hicieron posible la realización de estas obras (ver introducción general de la serie).

La recopilación de dibujos en papel cuadriculado es de J. Galarza, éstos se pasaron

en limpio por Jean-Baptista Faivre y Françoise Bagot para la primera edición y fueron corregidas y preparadas por J. Galarza, Jorge Pedraza, Lilianne Taboada y José Luis Dopazo. En esta segunda edición, los dibujos fueron capturados por Edith Hidalgo bajo la supervisión de J. Galarza

Dibujos Tradicionales...
Se terminó de imprimir en la
Ciudad de México en 1996 en
Impresora Gráfica del Centro S.A. de C.V.
Allende No. 33, Centro
México, D.F. Tel. 526 0440
Es una publicación de Joaquín Galarza
Se tiraron 300 ejemplares.

INTRODUCCION

Al llegar a Santa Ana Tlacotenco nunca pensé que existieran allí todavía, en 1971, artesanías tradicionales. Era difícil ver a primera vista aún entre las prendas femeninas cuáles pertenecían a la tradición y se hacían en el pueblo. Poco a poco, debajo de los percales, rebozos y chales industriales pude distinguir: fajas para enredos, cintas para el peinado, blusas tejidas y bordadas de chaquiras, puntas de cintas y de fajas de macramé y de chaquiras, etc. El primer domingo de mi estancia en el pueblo, una señora vino a ofrecerme en venta una ancha faja femenina tejida por ella. Mi sorpresa fue grande y más todavía, al ver que Irmgard Weitlaner, especialista en los tejidos mexicanos, no sabía que en la región de Milpa Alta se siguiera conservando el tejido tradicional. El telar de cintura y la urdimbre con "palitos" clavados en el suelo o fijos en un urdidor de madera lo siguen empleando las tejedoras de Santa Ana Tlacotenco y de Milpa Alta. Esta primera faja llegó muy a tiempo para que sus motivos pudieran figurar en el libro que ya casi listo para la imprenta tenía la maestra Weitlaner.

Durante mis estancias en Santa Ana Tlacotenco, de 1971 a 1974, fui adquiriendo enredos, blusas, rebozos, fajas y cintas femeninos así como calzones, camisas, fajas, huaraches y sombreros masculinos, para que una pequeña colección representara estas artesanías en el Museo del Hombre de París. Con ellas se montaron dos exposiciones: una en el pueblo (26 de Julio) y otra en Milpa Alta (15 de Agosto) en las fiestas principales, para que las admiraran los

habitantes y sobre todo las autoras, que nunca habían visto expuestos sus trabajos como obras de arte. A medida que obtenía fajas y cintas tejidas en relieve, brocado de dos y tres colores y terminadas en macramé y chaquira, iba copiando en papel cuadrulado los variados motivos. Estos se conservan únicamente en las viejas fajas y cintas. Las tejedoras conocen de memoria los motivos y no poseen cuadernos de modelos o muestrarios. Les prometí que les haría uno; por eso, espero que esta publicación les sirva para ese fin. Los motivos presentan además el interés de tener nombres en nahuatl o en español. Con estos constituimos un fichero que se publicará posteriormente. Aunque no faltan los motivos geométricos, la mayor parte de la inspiración de los dibujos procede de la observación de la Naturaleza, principalmente de los seres vivos: humanos, animales y vegetales. La "vista" es múltiple: de planta y de perfil y lo que es más sorprendente, en corte perpendicular. Así, pueden verse todas las partes constitutivas de flores y frutos. En estos elementos plásticos podemos encontrar semejanzas con las "imágenes" aztecas de los Códices, que me ayudaron a entender algunos aspectos del complejo espacio plástico tradicional.

PRESENTACION

Las láminas tienen una numeración corrida en números arábigos (1-295) y letras minúsculas cuando hay varios elementos en una página. Esta numeración sirve para identificar los dibujos individualmente con sus nombres en nahuatl y en español, en el cuaderno

correspondiente de texto.

Los dibujos se dividieron en los grupos siguientes: I Cielo: estrella II Tierra: 1. Seres humanos 2. Partes del cuerpo humano: corazón 3. Animales: Aves 4. Cuadrúpedos y otros animales 5. Plantas: Flores 6. Flores 7. Coronas y collares de flores 8. Frutos 9. Hojas 10. Guías floridas 11. Bases o soportes de ramos de flores 12. Motivos geométricos 13. Xonecuilli 14. Puntas: macramé (ver índice de láminas).

AGRADECIMIENTOS

En el volumen I de esta serie: Tlacotenco, Tonantzin Santa Ana. [C.I.E.S.A.S. Cuadernos, 49] citamos en detalle a las instituciones y personas francesas y mexicanas que hicieron posible la realización de estas obras (ver introducción general de la serie).

Los primeros dibujos sobre papel cuadriculado, en lápiz y pl^umón son de J. Galarza, sólo algunos se publican aquí; estos los pasaron en limpio: Jean-Baptiste Faivre y Françoise Bagot. Las fotocopias que conservamos nosotros, recuerdo de dos exposiciones y que sirvieron para esta edición, fueron corregidas y preparadas por: J. Galarza, Jorge Pedraza, Lilianne Taboada y José Luis Dopa^zo.



SEMINARIO DE ESCRITURA INDIGENA TRADICIONAL

Índice	
Introducción	I
Telar de cintura y urdidor fijo	3
CIELO: Ilhuicatl	4
TIERRA	
Seres Humanos	6
Partes del cuerpo humano	
Corazón: Yolotl	9
ANIMALES EN GENERAL	
Aves: Totol	11
Cuadrúpedos y otros animales	17
Techelotl, tochtli, etc.	
PLANTAS	
Flores:Xochitl	22
Coronas y collares de flores	36
Xochicozacatl	
Frutos: Xocotl	37
Hojas: Ihuitl	40
Guias floridas	47
Bases o soportes de ramos de flores	54
MOTIVOS GEOMÉTRICOS	56
Varios: Milteca	
XONECCUILLI	61
PUNTAS: Macramé	64

TELAR DE CINTURA TRADICIONAL

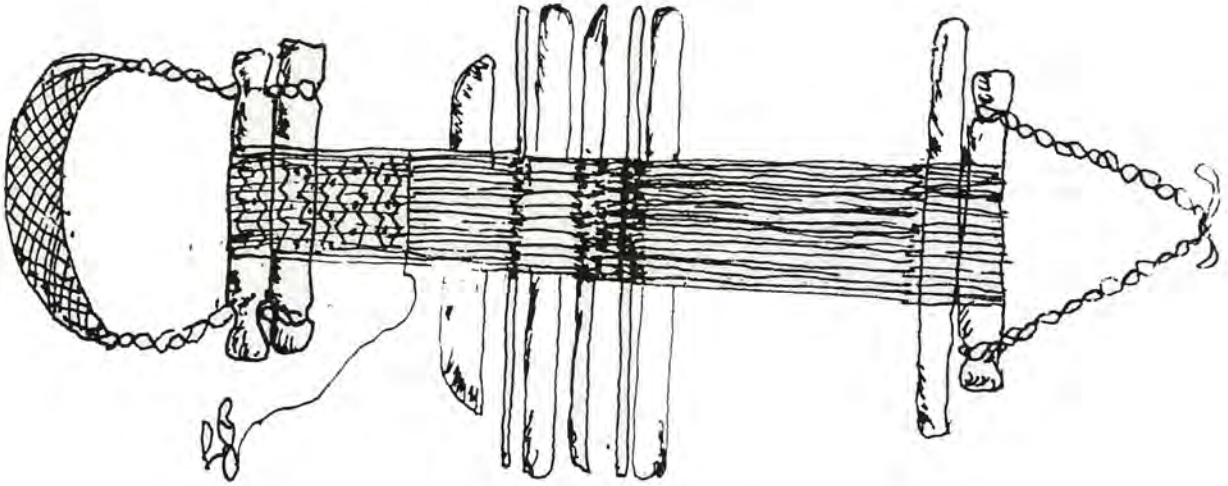

URDIDOR FIJO

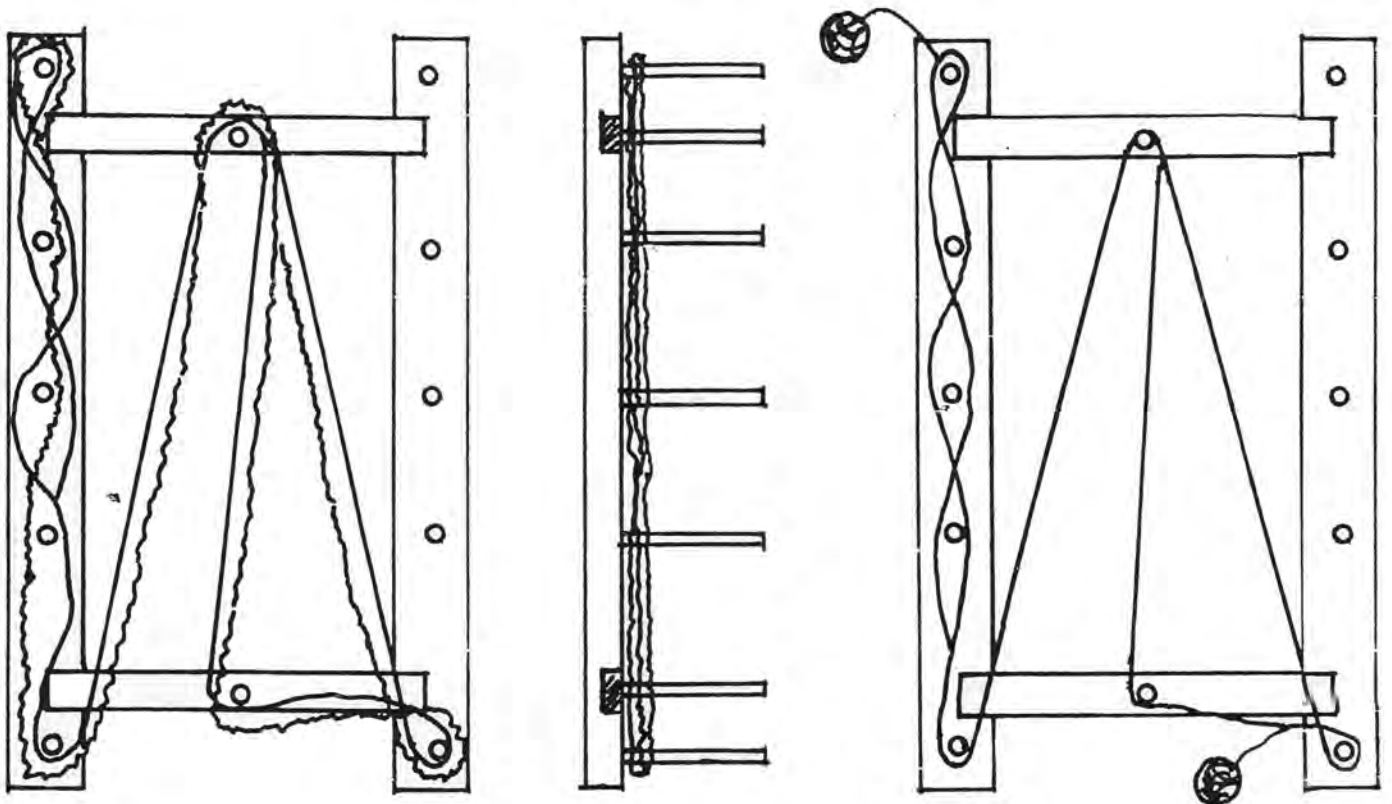

CIELO-ILHUICATL:
Estrelia-Citlalli

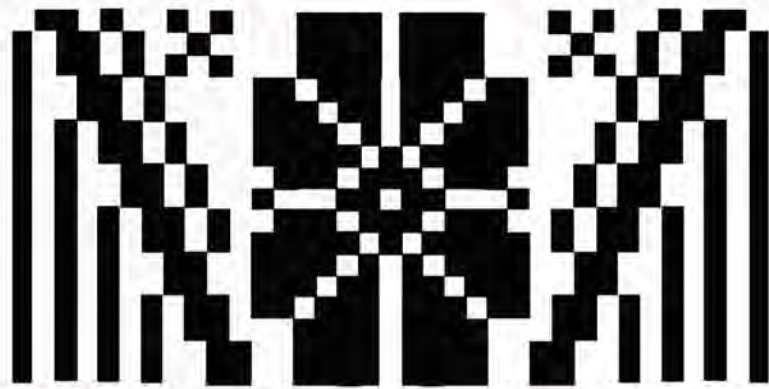

1



2

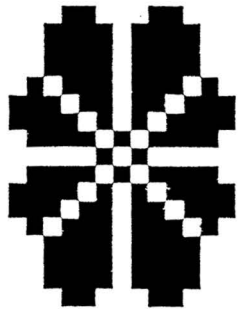

3.

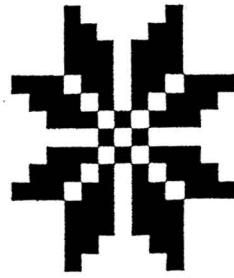

4.

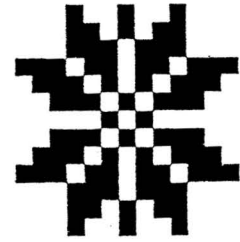

5.

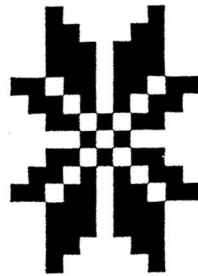

6.

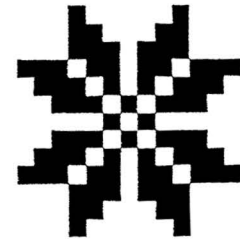

7.

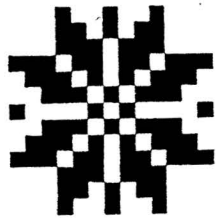

8.

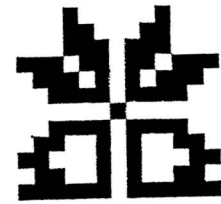

10.

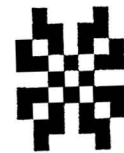

11.

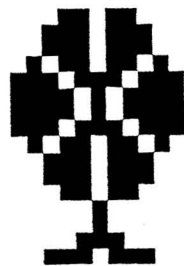

9.



12.

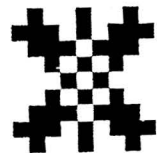

13.



TIERRA:
Seres humanos
Hombre-*Tlacatl*
Mujer-*Cihuatl*

1.

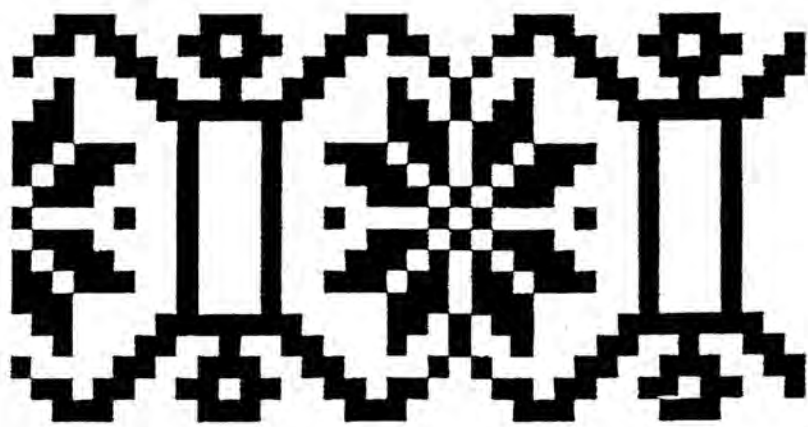

2.

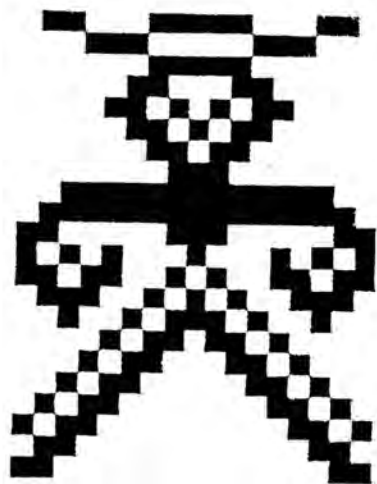

4.

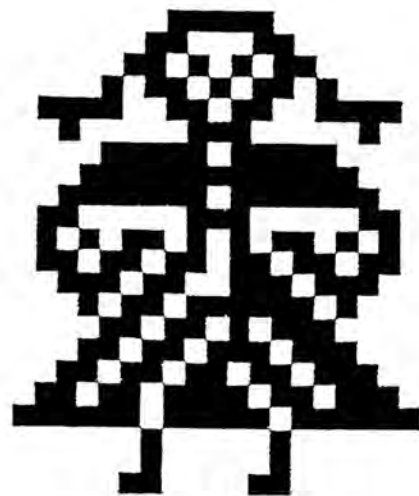

3.

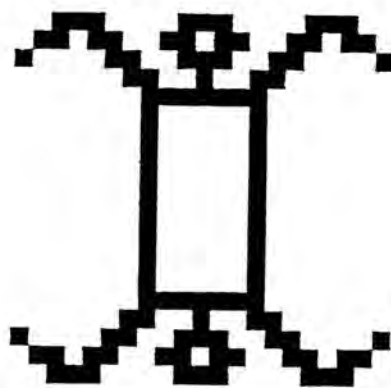

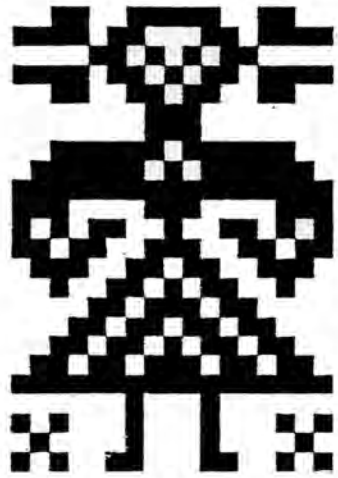

5.



6.



7.

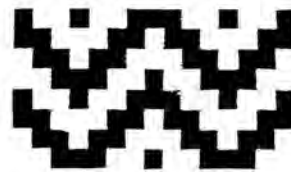

8.

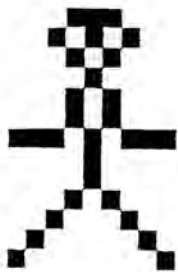

PARTES DEL CUERPO HUMANO:
Corazón-Yolotl



1.

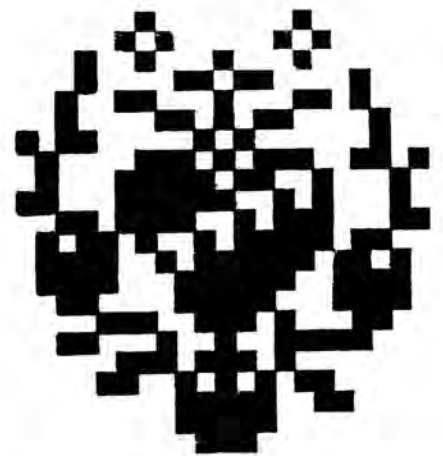

2.

3.

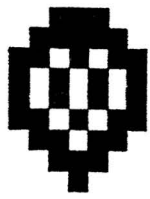

6.



4.

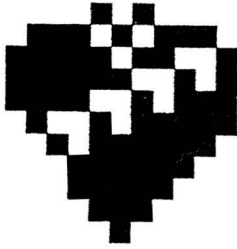

5.

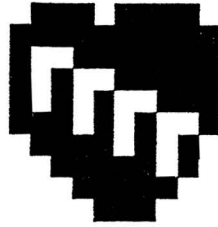

7.

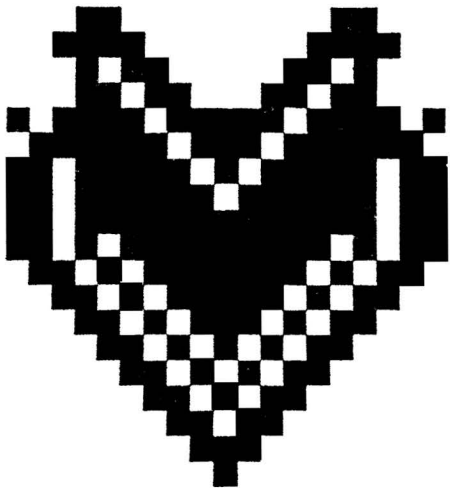

8.

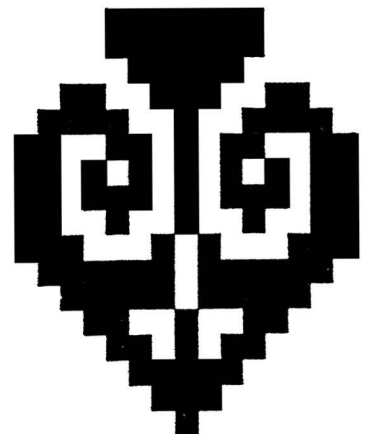

ANIMALES EN GENERAL:
Aves-Tototl





1.



2.



3.

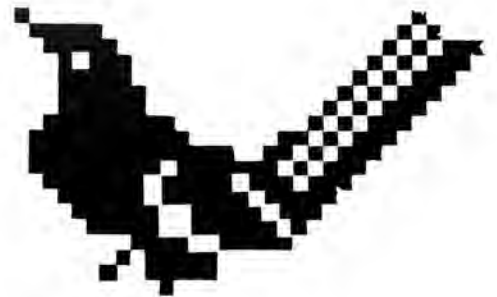

4.



5

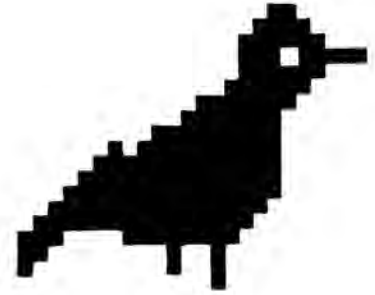

8



6



7



9



11

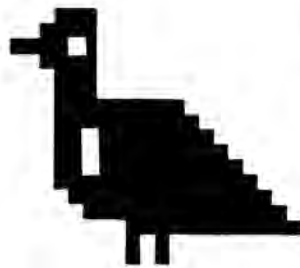

10



12



13

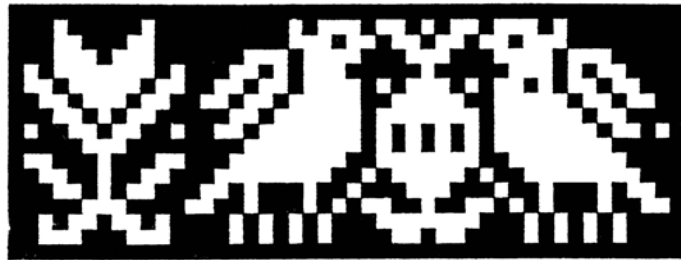

14



15



16

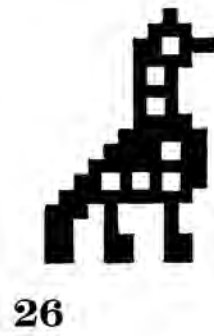
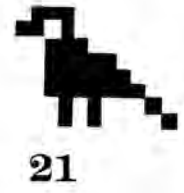
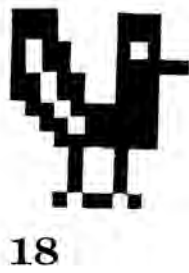

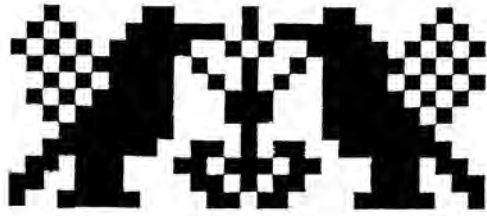

28



29

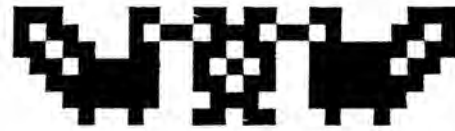

30

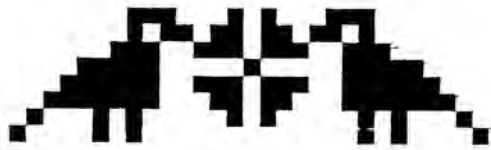

31

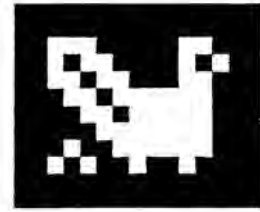

32



33



34

CUADRUPEDOS Y OTROS ANIMALES:
Techelot , Tochtl,, e c.

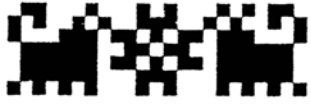

1



2



3

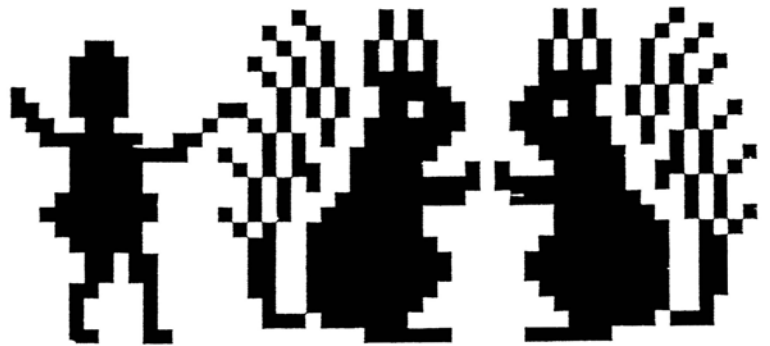

4



5



6



7



9



8



10

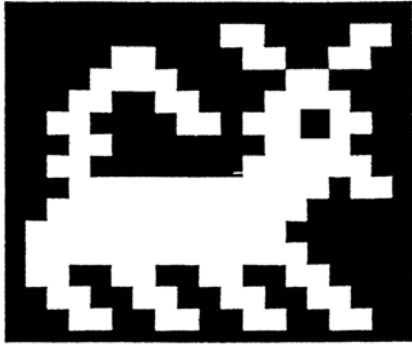

11



12

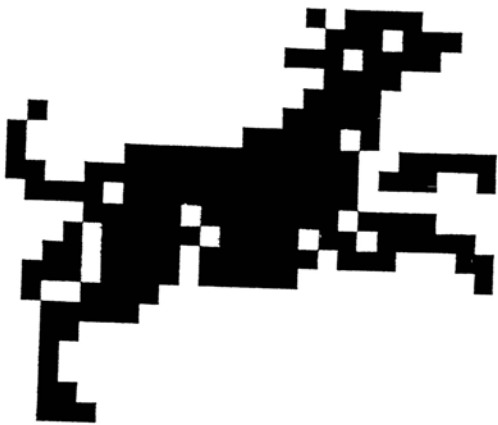

13



14

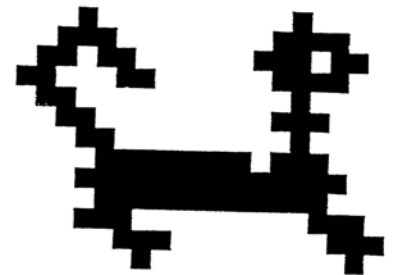

15



16



17



18

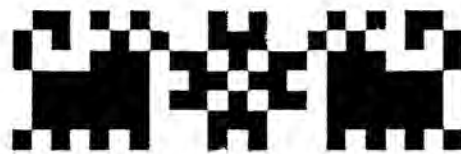

19



20

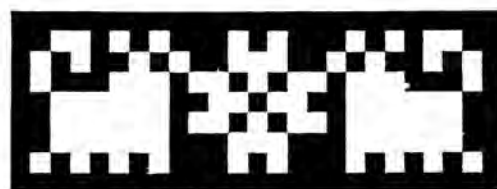

21



22

PLANTAS
FLORES-*Xochitl*





1



2



3



4



5



6

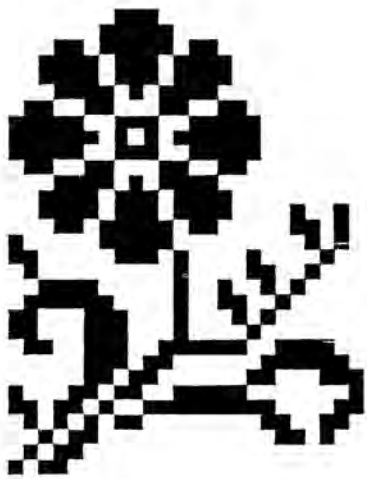

7



9

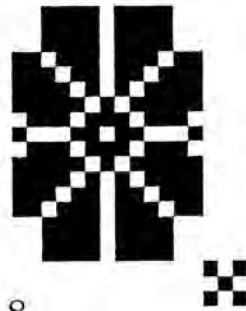

8

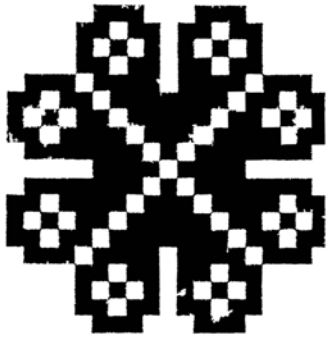

10



12

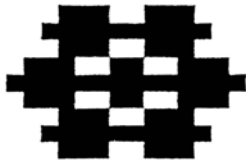

11



13

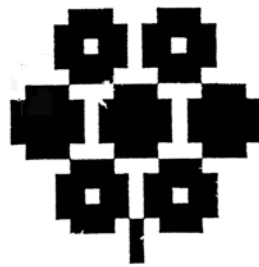

14

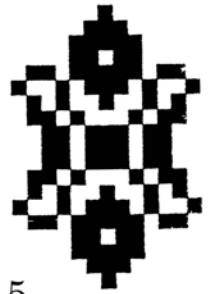

15

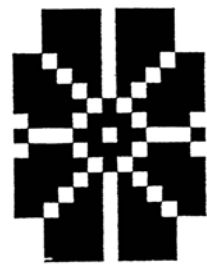

16

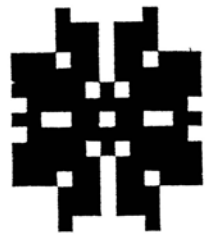

17

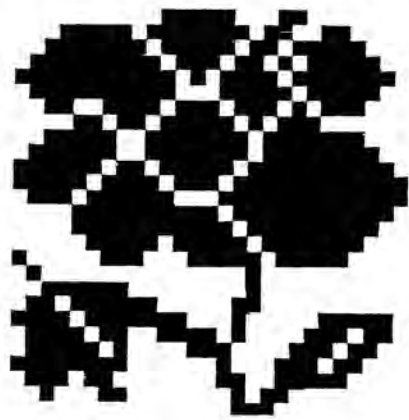

18



19



20

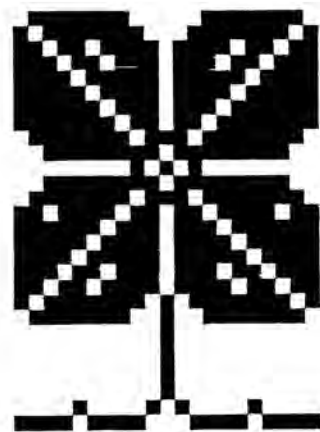

21



22

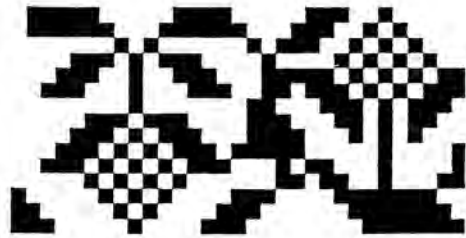

23

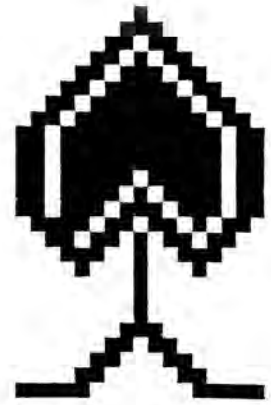

24



25



27

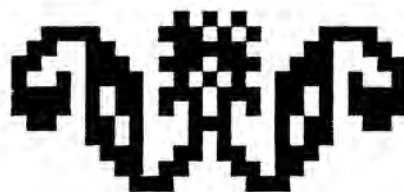

26

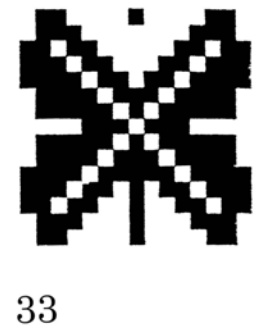
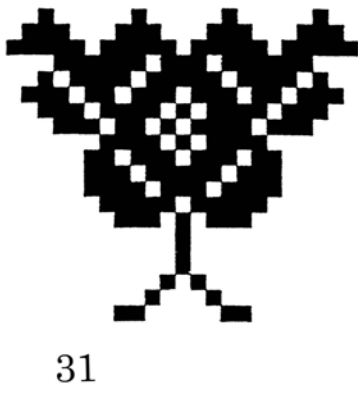
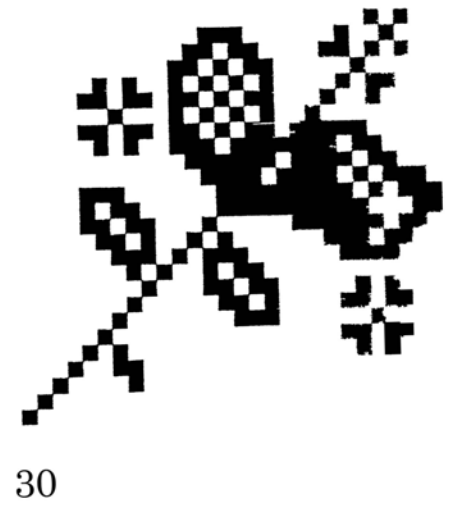
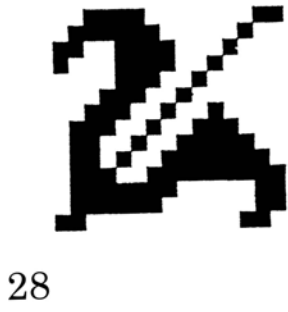

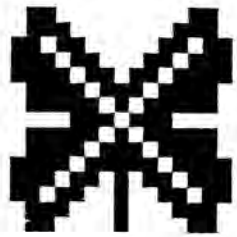

34



36



37



35



38



39



40



41

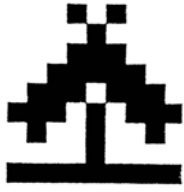

42



43



48

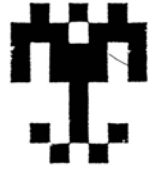

49

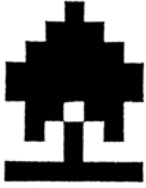

44



45



50



46



47



51

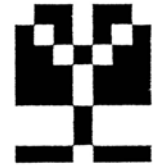

52



53



54



55



56



57

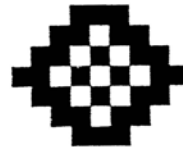

58

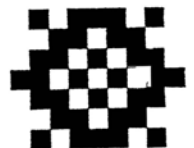

59

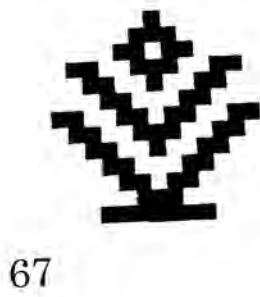
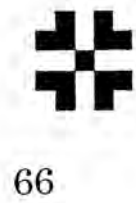
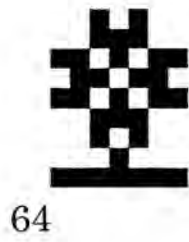
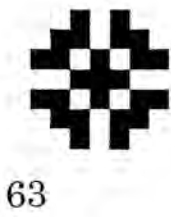
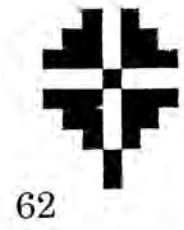
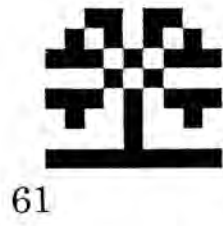
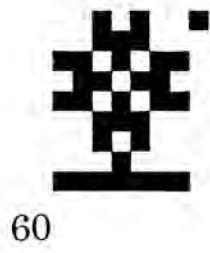

70.



71.



72.



73.



75.



74.



76.



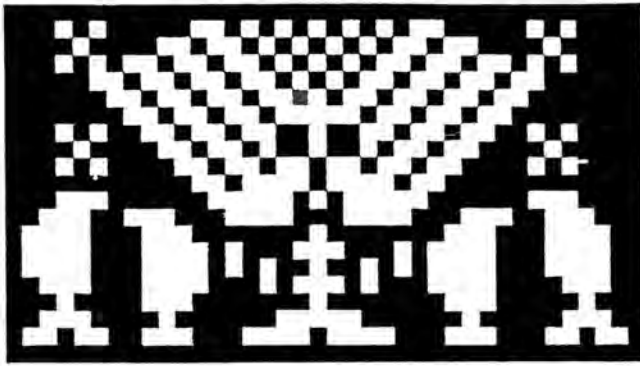

77



78

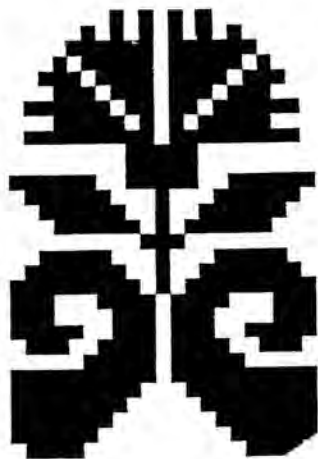

79



80

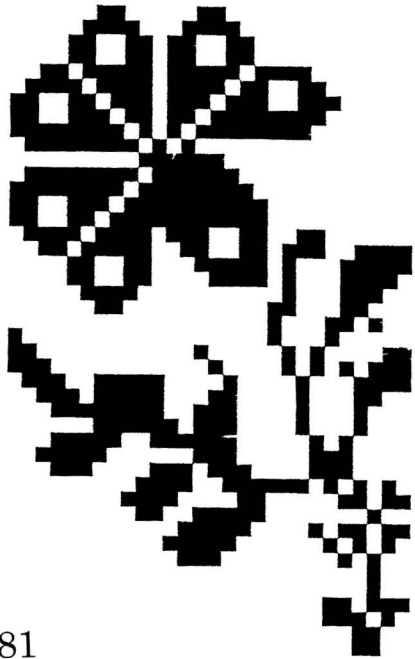

81

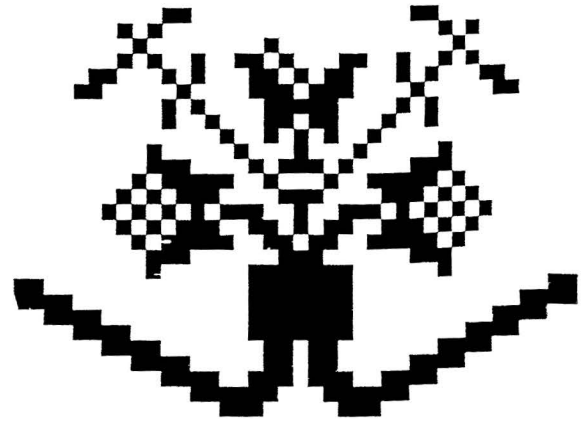

82

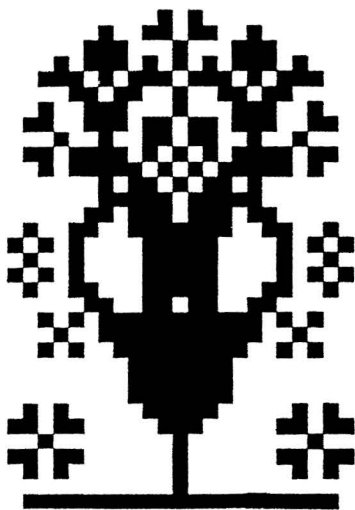

83



84

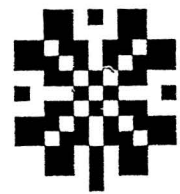

85

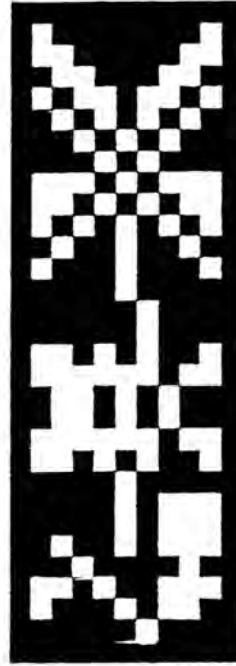
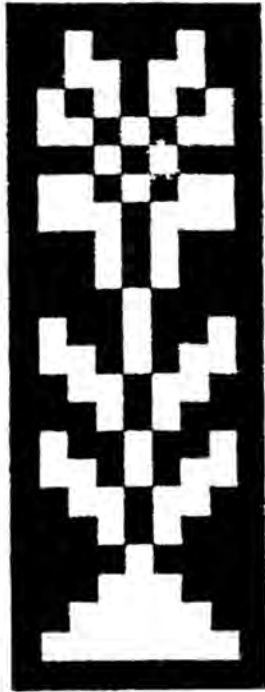

87

88

89

86

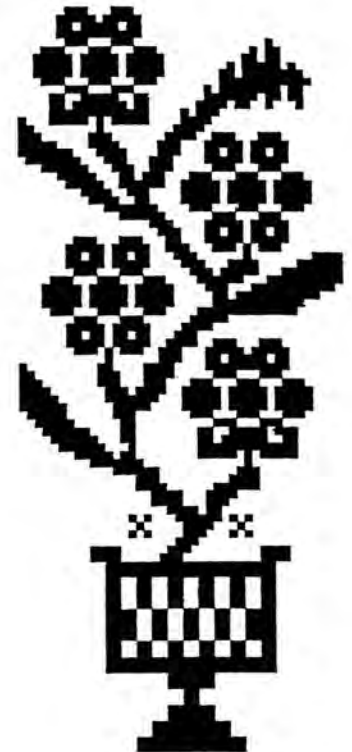

90

91

92

93

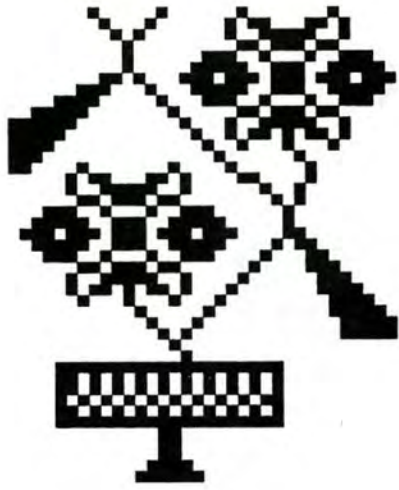

94.



95.



96.

CORONAS Y COLLARES DE FLORES

Xochicozacatl



1.



2.

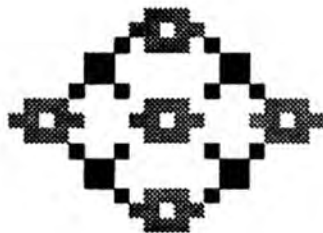

3.

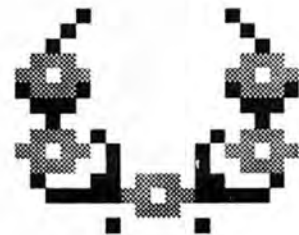

4.

FRUTOS
Xocotl



8.



1.



2.



3.

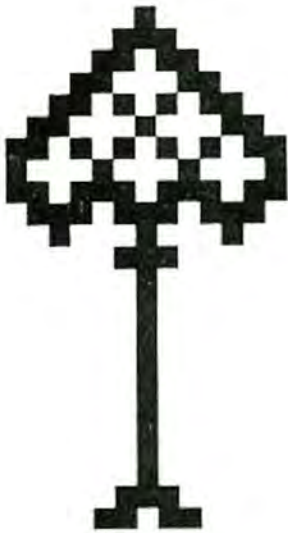

4.



5.



6.

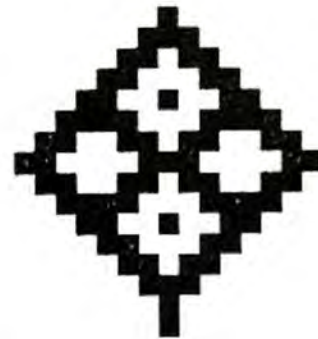

7.



8.



9.

10.



11.



12.



13.

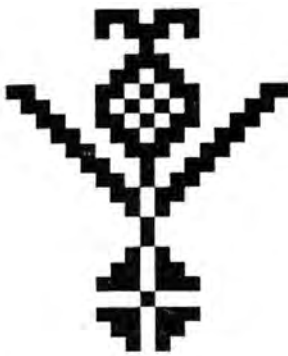

14.



17.



15.



16.



18.



HOJAS
Ihuatl



1.

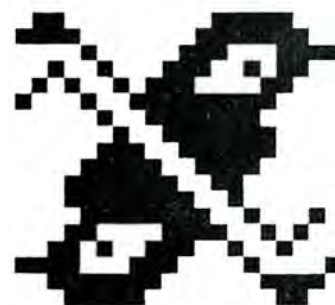

2.

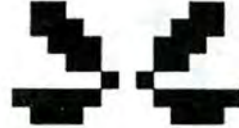
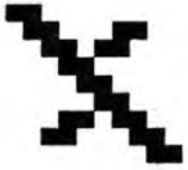
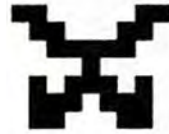
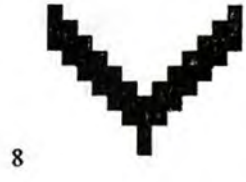
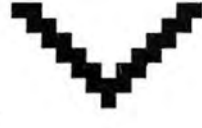
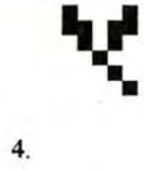
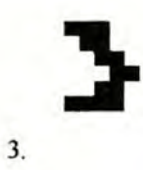



18.

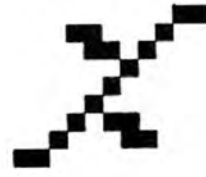

19.



20.



21.

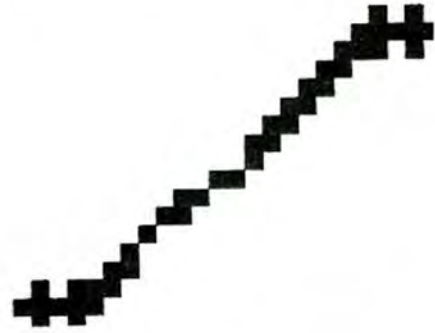

22.



23.



24.



25.



26.

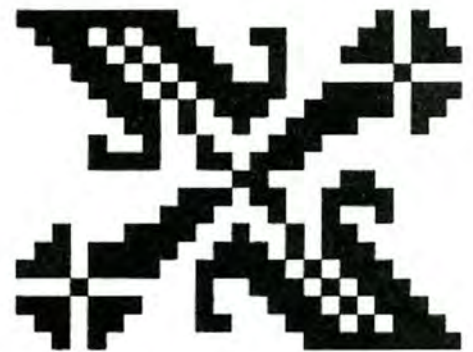

27.



28.



29.



31.



33.

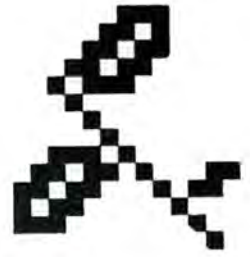

30.

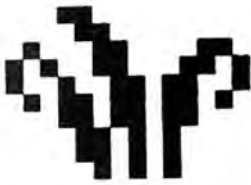

32.



34.



35.



36.

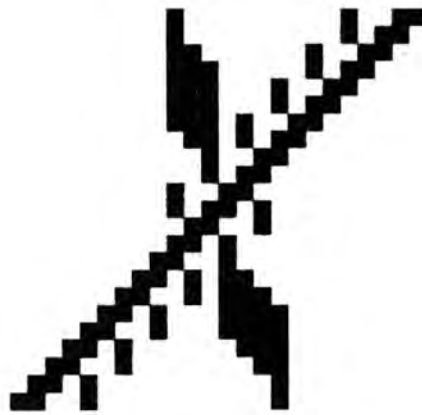

37.



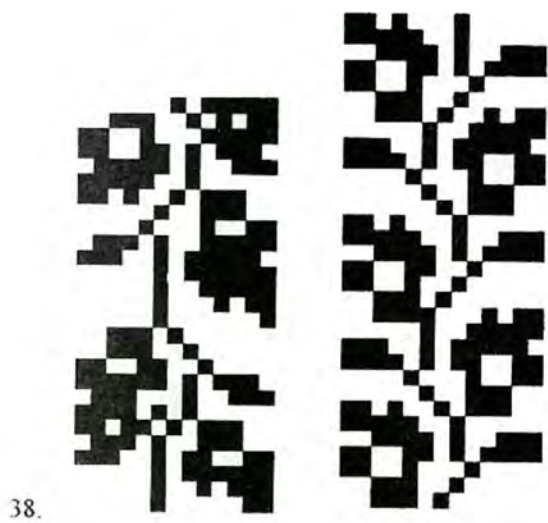

38.



39.

40.

41.

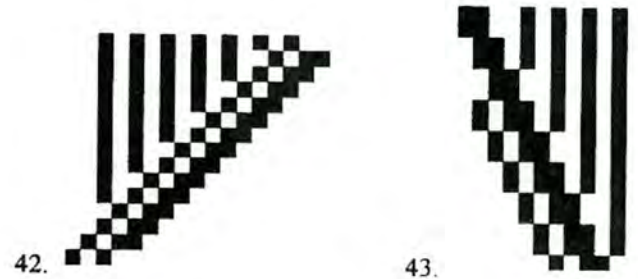

42.

43.



44.



45.



46.



52.



53.



56.

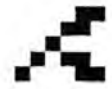

57.



54.

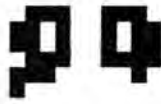

55.



58.



59.



47.



49.



51.



48.



50.

60.



61.



62.



63.



64.



65.



66.



67.



GUIAS FLORIDAS



1.

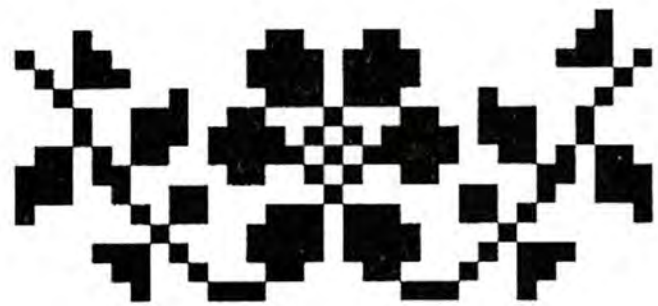

3.

4.



5.



6.



7.



8.



9.



10.



11.



12.



13.



14.

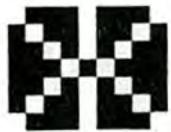

15.



16.



19.



17.



20.



18.

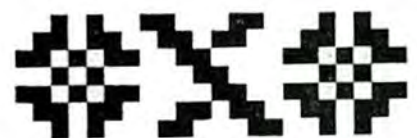

21.



22.



23.



24.



25.



26.



27.

28.

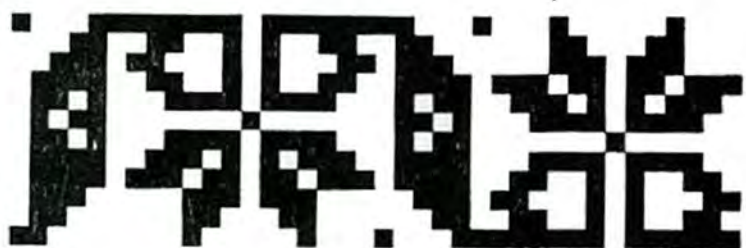

29.



30.



31.

32.



33.

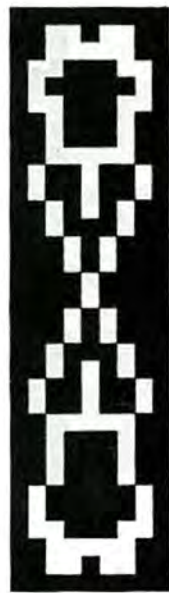

34.



35.



36.



37.



38.

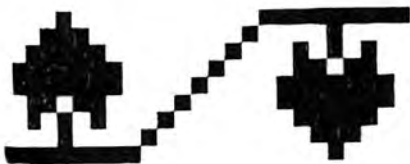

39.

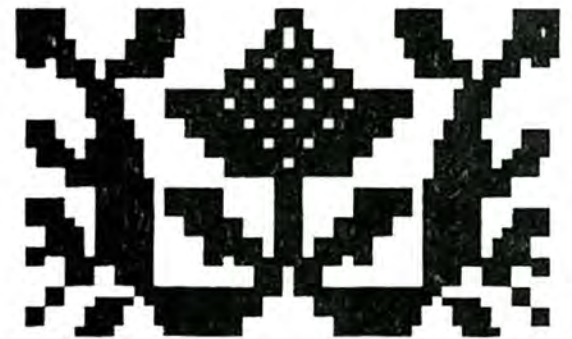



40.



43.



41.



44.



42.



45.

46.

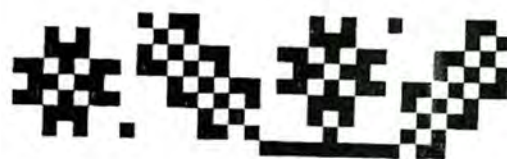

49.

47.



50.

48.





51.

BASES O SOPORTES DE RAMOS DE FLORES



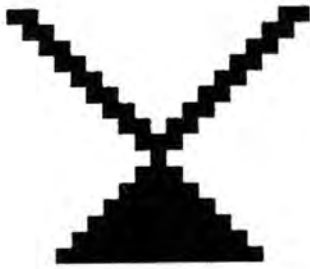

5.



8.



6.



7.



9.



10.



11.



13.



12.



14.

MOTIVOS GEOMÉTRICOS
Varios-Milteca

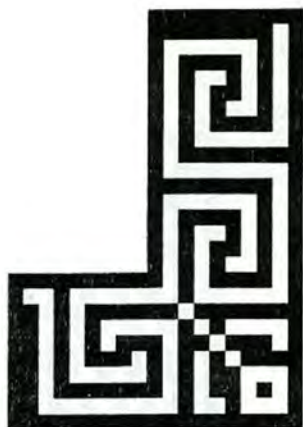

1.



2.



3.



4.

5.



6.

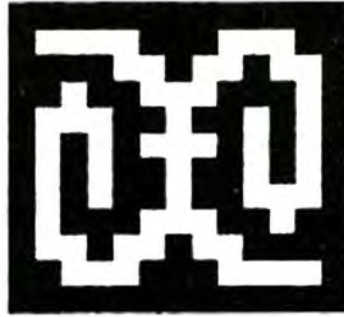

8.

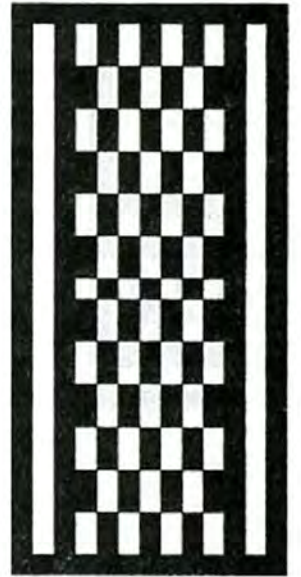

7.

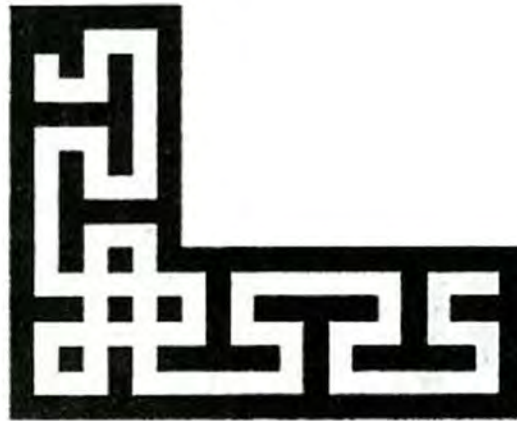

9.

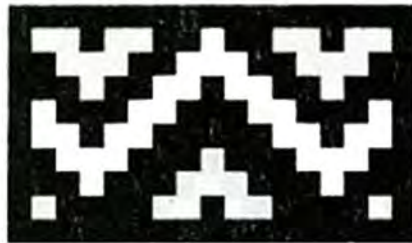

10.

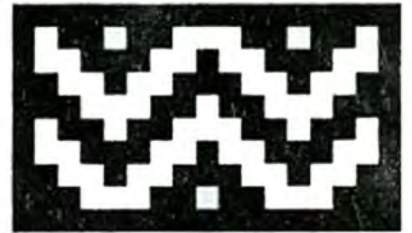

11.



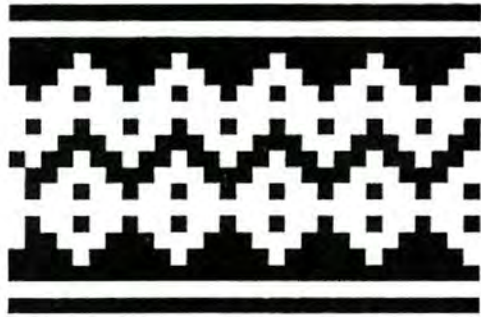

12.



14.

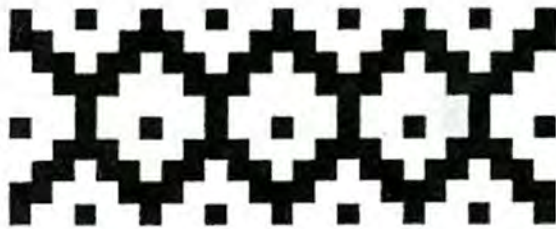

13.



15.



16.



17.



18.



19.



20.



21.

22.

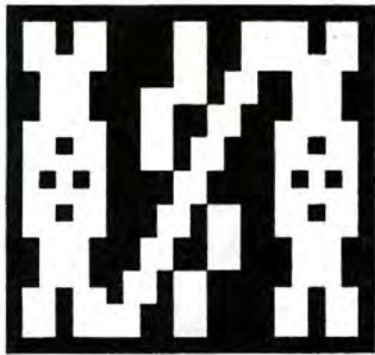

23.

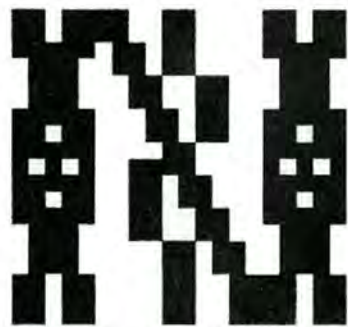

24.

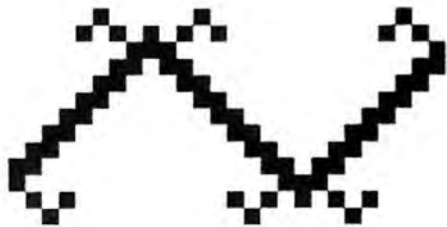

25.

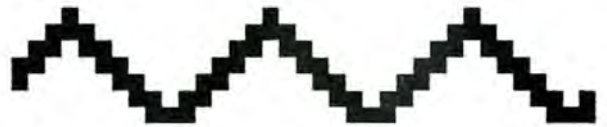

26.



29.



31.



27.



30.

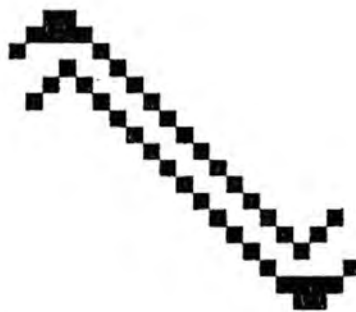

32.

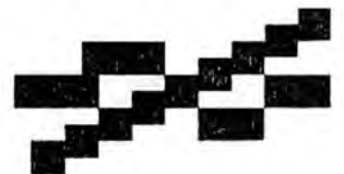

28.



33.



34.

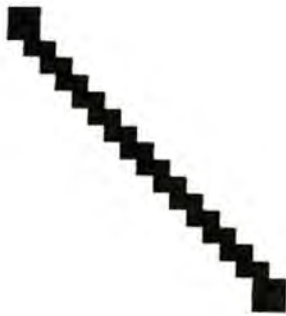

35.



36.



37.



38.



40.



43.



44.



39.

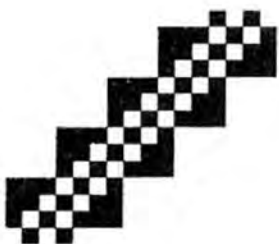

41.



45.



42.

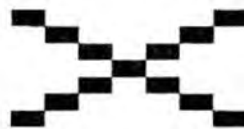

46.



47.



XONECUILLI

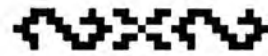

1.

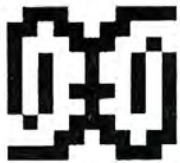

3.



2.



4.





5.

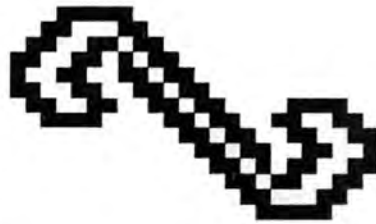

8.



6.



9.

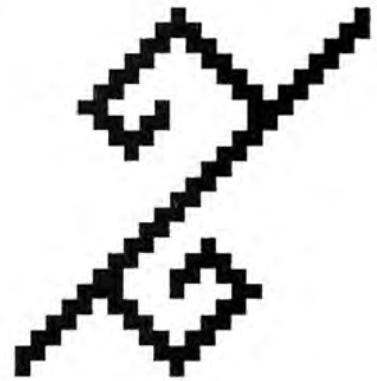

11.

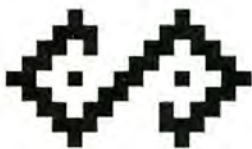

7.



10.

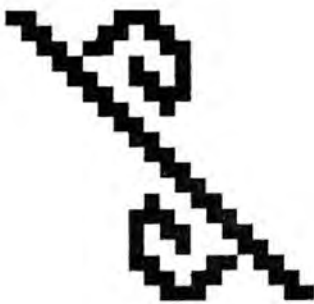

12.



13.



15.



14.

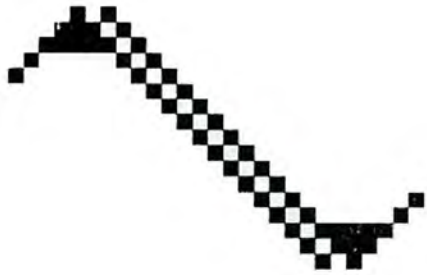

16.



17.



18.



19.



20.

21.

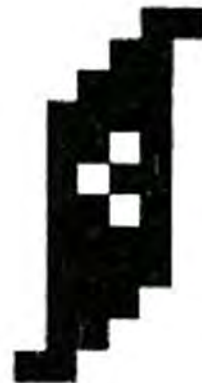

**PUNTAS:
MACRAME**

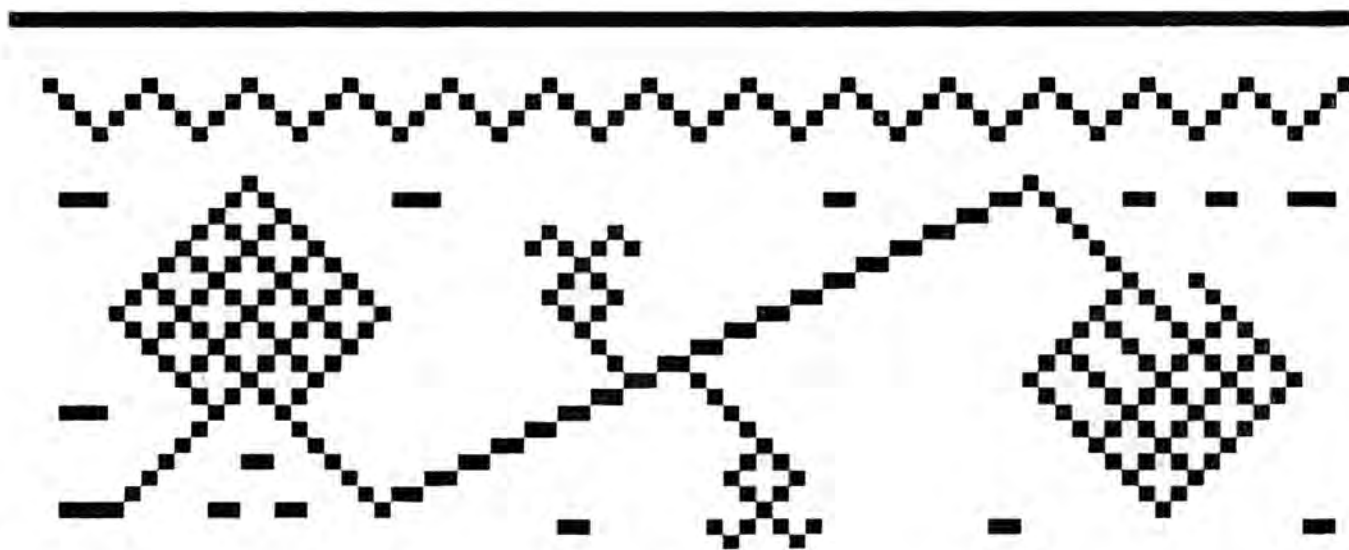

1

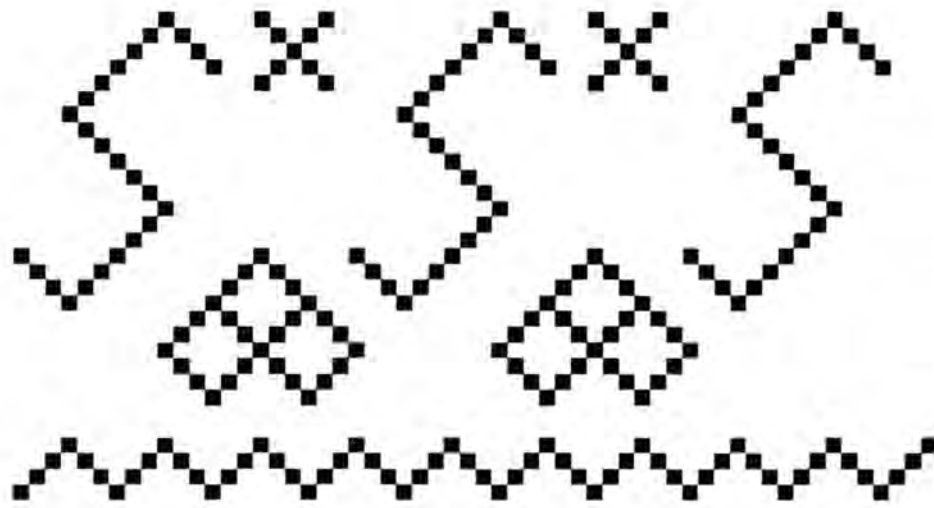

2.

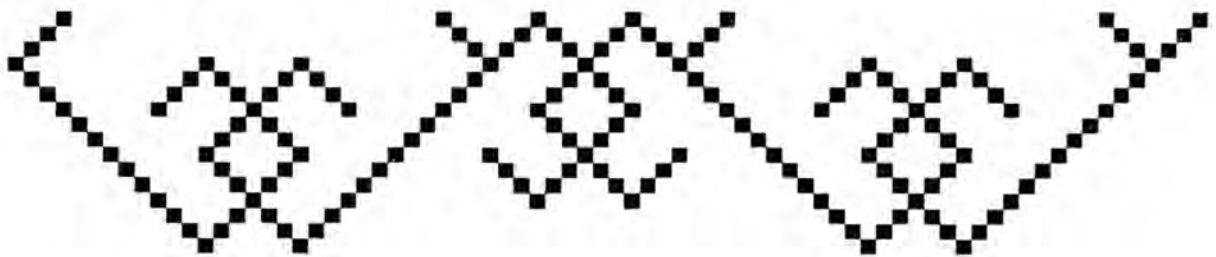

3.